

LES SUPERSTRUCTURES

COMMENT CHOISIR SA SUPERSTRUCTURE

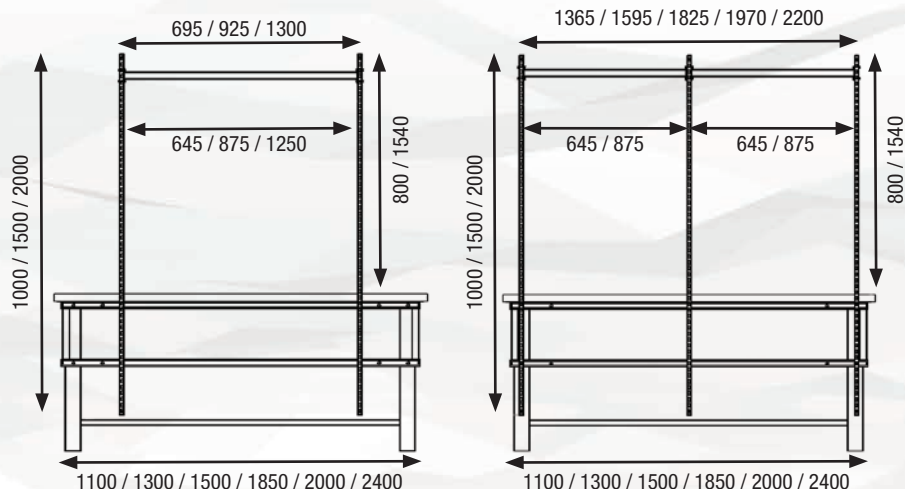

COLORIS
RAL 9002

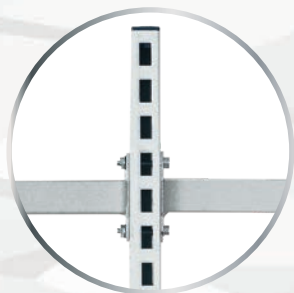

Longueur
plateau

695	925	1300	1365	1825	1595	1970	2200
645	875	1250	645 645	875 875	645 875	645 1250	875 1250

1100 mm	✓	✓						
1300 mm	✓	✓						
1500 mm	✓	✓	✓	✓				
1850 mm	✓	✓	✓	✓				
2000 mm	✓	✓	✓	✓	✓	✓		
2400 mm	✓	✓	✓	✓	✓	✓	✓	✓

CADRE ARRIÈRE

Le cadre arrière se fixe sur les établis ATS 700 ATS 800 / UNIVERSEL permettant la fixation des superstructures.



DIMENSIONS	RÉFÉRENCES
L → 1020 x H ↑ 350 mm poste de 1100 mm	35.450.2001
L → 1260 x H ↑ 350 mm poste de 1300 mm	27.453.2001
L → 1420 x H ↑ 350 mm poste de 1500 mm	35.451.2001
L → 1710 x H ↑ 350 mm poste de 1850 mm	40.365.2001
L → 1920 x H ↑ 350 mm poste de 2000 mm	35.452.2001
L → 2320 x H ↑ 350 mm poste de 2400 mm	27.455.2001



COLORIS
RAL 9002

PLATINE de FIXATION

Se fixe sur les plateaux à l'aide de vis et écrous



DIMENSIONS	RÉFÉRENCE
L → 80 x P ↗ 100 x H ↑ 200 mm	35.850.2002